



## **KITESURF WORLD CUP SYLT** **GKA KITE-SURF WORLD CUP GERMANY 2019**

*It is a pleasure to announce the fourth event of the GKA KITE WORLD TOUR 2019 which will be a*

**3-STAR KITE-SURF WORLD CUP\***

*held in Westerland on the island of Sylt in GERMANY.*

The dates will be from the 25<sup>th</sup> to the 30<sup>th</sup> of June 2019.

This is a 3-Star GKA event and the competition is sanctioned and governed by the 2019 GKA KSWT Rulebook.

### **Registration**

#### **Entry procedure and Registration**

All competitors planning to enter a KWT event shall pre-register through the registration link on the dedicated event page on the GKA Kite World Tour website:

<https://www.gkakiteworldtour.com/register/>

or via email to [tom@global-kitesports.org](mailto:tom@global-kitesports.org) or by other means to be specified by the KWT Sports Commission, no later than the published closing date for entries for that specific event.

Ultimately it is the competitors' responsibility to pre-register or to apply for an entry for an event and to ensure that the application has been received timely and correctly.

According to rule 11.2, fines and/or having their next events applications cancelled may be handed out to a pre-registered and / or qualified competitor who, without advanced notice fails to show up at an event.

Complete and signed entry forms for event registration must be signed and complete by the time stated in the Race Notice. Exceptions can only be granted by the KWT Representative.



If a competitor is unable to complete registration at the published time and place in the Race Notice for reasons beyond their control, then the competitor should contact the KWT Representative with details of their delay, and must gain consent for their registration period to be extended. Evidence must be supplied to support reasons showing that the circumstances were out of the competitor's control. Failure to comply with the above will prohibit a competitor from entering the event.

All riders can register for the event through the online form or by mailing to [tom@global-kitesports.org](mailto:tom@global-kitesports.org) **by 23.59h of the 11th of June 2019.**

The registration mail should contain:

- Full Name:
- Nationality:
- Hometown:
- Age:
- Federative License Number:
- Sponsors:
- Passport number:
- Telephone/Whatsapp:
- Facebook page:
- Instagram account:
- Email:
- Name of Caddy:
- Food specifics:
- COMPLETE FLIGHT DETAILS OF ARRIVAL AND DEPARTURE:

All attending riders need to be members of a national NATIONAL SAILING FEDERATION and/or WORLD SAILING and have to be insured via the NATIONAL SAILING FEDERATION and/or WORLD SAILING.

Cost of entry is 120.- Euro via Wire Transfer to the GKA Bank account below and 160.-Euro or 180.-USD cash on site. Please bring exact quantities if payment is to be made on site.



Bank transfer payments have to be done to the following account:

GKA Event GmbH  
IBAN: DE75 2005 0550 1002 3050 17  
BIC/Swift: HASPDEHHXXX

Bank Address:  
Hamburger Sparkasse  
Adolfplatz / Gr. Burstah  
20457 Hamburg, Germany

*Bank transaction costs are going to the account of the SENDER/ORGANIZER/OBLIGOR.*

**Please make sure to put the full name of the rider and the name of the event in the transfer's subject.**

All registration payments must be made before the 12th of June 2019 and credited to the GKA bank account latest 7 days prior to the event. Bank transaction-costs are paid by the rider.

#### **Entry restrictions**

Inscription-fee payments must be made no later than the end of the inscription-time at the respective event.

In the case that the full amount of the inscription fee is not paid by the end of the announced inscription-time, the rider will not be allowed to compete.

Payments can be made in cash at the inscription at the respective event.

Cash-payments will only be accepted in Euros or USD currency!

The maximum number is 32 male competitors and 32 female registered for this KWT event, including the wildcards.

#### **Disciplines**

There will be just one Official Discipline (Wave & Strapless Freestyle Kitesurfing) in a KSWT event with the following categories:

- Wave
- Strapless Freestyle

Both categories can be used in any event, even in the same elimination depending on the conditions.

Divisions:

- Pro Men: any age (minimum 14 years old in the year of competition)
- Pro Women: any age (minimum 14 years old in the year of competition)



## IMPORTANT INFO

Competitors have to wear the official lycra at all times when proceeding to the water – also during training – for optimal recognition above the harness. Competitors will get their names printed on your personal lycra during registration by Andreas Velbinger from Tramontana Grafixx. Each rider will get one black and one white competition riders' vest at the registration. Each rider is responsible for his competition riders' vests. In case of loss a replacement is not possible! Competitors shall wear an event advertising lycra vest supplied by the Event Organizer over all other clothing, including harness on the water at all times during the event and four (4) board stickers to be placed on top and on the bottom of the board on each board.

1. Lycra/Competitions Riders' Vest **over the harness.**





- Assigned board sticker, two stickers on the top deck of the board and two on the bottom (see picture – positions may change). Andreas Velbinger from Tramontana Grafifix will help you to apply the stickers correctly – he will be also your contact person during the event in case you have lost one sticker.

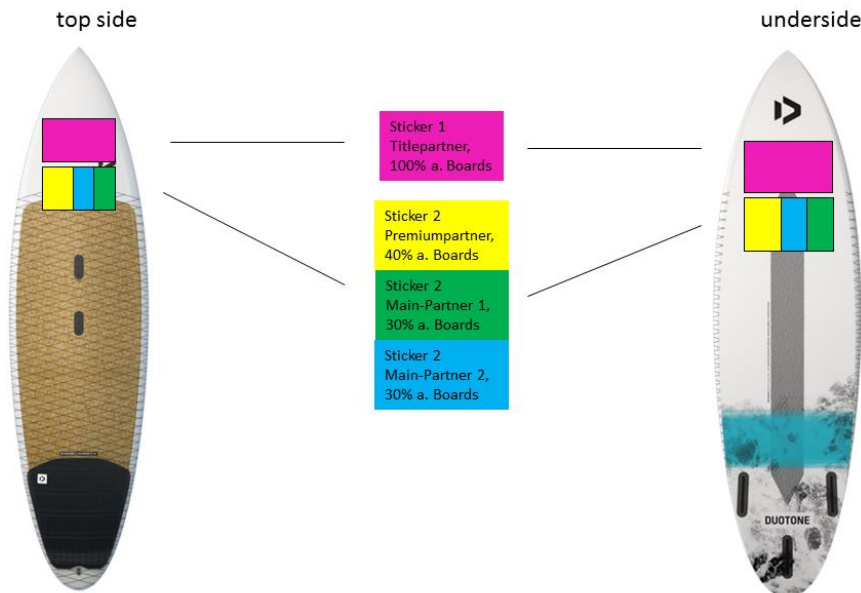

All competitors are required to abide by the advertising rules as laid out in the Rule Book. Competitors breaching these rules may be warned in writing for the first offence and may incur a fine at the second offence of not more than \$ 500 for each violation. Repeated offenders may be disqualified from the Event and/or Series.

All rider meetings and opening/closing ceremonies in the schedule are mandatory to all riders. Please be on time and ready.

There will be free breakfast and lunch provided for all competitors.

Each rider is entitled to register one caddy. Caddies will not have free access to the Riders Lounge! Caddies will only have access to the launching area and the equipment tent, to help their fellow riders with their kite equipment, starting and landing. Caddies wanting access to the Competitors Lounge have to pay a fee of 75.-EUR cash at the registration day (max. 1 Caddy per Rider). This will include breakfast, lunch and drinks during the competition days. Cash payments will only be accepted in Euros.

The Riders ID-Strap authorizes you to enter the beach area free of charge, the equipment storage tent, the launching area and the Competitors Lounge. You will receive the Riders ID-Strap personally and only at the registration.

The Competitors Lounge will be open for riders, legitimate caddies, GKA and legitimate employees only. You will be able to enter the Competitors Lounge with your personal ID-Strap. Opening time will be every day from 09.00h until minimum 19.00h or approximately one hour after the last heat.



Riders are not permitted to publicly associate their names in non-authorized parties/autograph sessions.

There will be a social event-calendar for each event that all riders have to join via social media and share.

Please use these media hash tags for all social media posts:

#kitesurfworldcupstylt #kitesurfworldcup #GKAstylt #GKAkitemorldtour, #GKAkitesurf, #GKAstrapless

You can find additional event information on the official website: [www.kitesurfworldcup.de](http://www.kitesurfworldcup.de) and in separate document "Riders Info KSWC 2019"

### Equipment storage

There will be secure storage for all riders' equipment at the equipment storage tent from Tuesday, the 25<sup>th</sup> of June until Monday, the 1<sup>st</sup> of July 2019. Access only allowed with valid Rider/Caddy ID-Straps.

### Travel info:

#### Airports:

Sylt (GWT): mainly domestic flights, some international connections.

Hamburg (HAM): there are plenty of daily international flight connections.

#### By train:

Take a train from Hamburg-Airport to Hamburg-Altona and then to Westerland (Sylt). The train takes about 3 hours and is operating between 6.00 and 21.00. For exact times check the train schedule:

[www.diebahn.de](http://www.diebahn.de)

#### By car:

From Hamburg it is about 3 hours drive by car. You need to get to Niebüll, then take a car train (DB Sylt Shuttle) to reach the island of Sylt.

[www.syltshuttle.de](http://www.syltshuttle.de)

If you are travelling by car you can get a voucher for the car transport train (DB AutoZug). You will get a discount around 25%. This voucher is **ONLY** for the car transport train **NOT** for the normal train. If you would like to have a voucher please email to: [douven@act-agency.com](mailto:douven@act-agency.com)

**Deadline: not later than 7th of June 2019!**

The adress of the GKA Kitesurf World Cup Sylt:

Brandenburger Strasse/Brandenburger Platz  
25980 Westerland, Sylt



**Visa:**

For visa info please email: [tom@global-kitesports.org](mailto:tom@global-kitesports.org)

**Weather:**

Sylt has a northern Europe climate, so weather conditions are rather mild in June. The air temperature during day can be between 25°C the highest temperatures and lowest of 12°C. The water temperature of the North Sea is around 14°C, so bringing a wetsuit and a jacket is recommended! Sunrise is 05.00h and sunset is 22.00h.

**Wind direction**

Westerly winds blowing 15-35 knots onshore at Westerland.  
Easterly winds blowing around 12-25 knots offshore at Westerland.

**Event Schedule**

**Tuesday, 25<sup>th</sup> June 2019**

09.00: Breakfast @ Competitors Lounge  
10.00: Event start, event radio & side events  
10.00-12.00: Registration for riders in the equipment tent at the parking  
13.00: Skippers Meeting  
13.00-15.00: Lunch @ Competitors Lounge  
13.30-19.00: Kitesurf competition: GKA Kite-Surf World Cup  
22.00h: End of event

**Wednesday, 26<sup>th</sup> June 2019**

09.00: Breakfast @ Competitors Lounge  
10.00: Event start, event radio & side events  
10.00-19.00: Kitesurf competition: GKA Kite-Surf World Cup  
13.00-15.00: Lunch @ Competitors Lounge  
22.00: End of event

**Thursday, 27<sup>th</sup> June 2019**

09.00: Breakfast @ Competitors Lounge  
10.00: Event start, event radio & side events  
10.00-19.00: Kitesurf competition: GKA Kite-Surf World Cup  
13.00-15.00: Lunch @ Competitors Lounge  
22.00: End of event



### **Friday, 28<sup>th</sup> June 2019**

09.00: Breakfast @ Competitors Lounge  
10.00: Event start, event radio & side events  
10.00-19.00: Kitesurf competition: GKA Kite-Surf World Cup  
13.00-15.00: Lunch @ Competitors Lounge  
22.00: End of event

### **Saturday, 29<sup>th</sup> June 2019**

09.00: Breakfast @ Competitors Lounge  
10.00: Event start, event radio & side events  
10.00-19.00: Kitesurf competition: GKA Kite-Surf World Cup  
13.00-15.00: Lunch @ Competitors Lounge  
22.00: End of event N-JOY THE PARTY

### **Sunday, 30<sup>th</sup> June 2019**

09.00: Breakfast @ Competitors Lounge  
10.00: Event start, event radio & side events  
10.00-15.00: Kitesurf competition: GKA Kite-Surf World Cup  
13.00-15.00: Lunch @ Competitors Lunch  
16.00: Prize giving ceremony: GKA Kitesurf World Tour  
17.00: End of event

#### **Side events daily:**

Kitesurf and SUP fair, Pumptrack, Backyard Wave, ...

Be aware that times of competition can change and will depend on weather conditions. Skippers Meeting for the following day will always be communicated at the end of the previous day!





**Location map:**

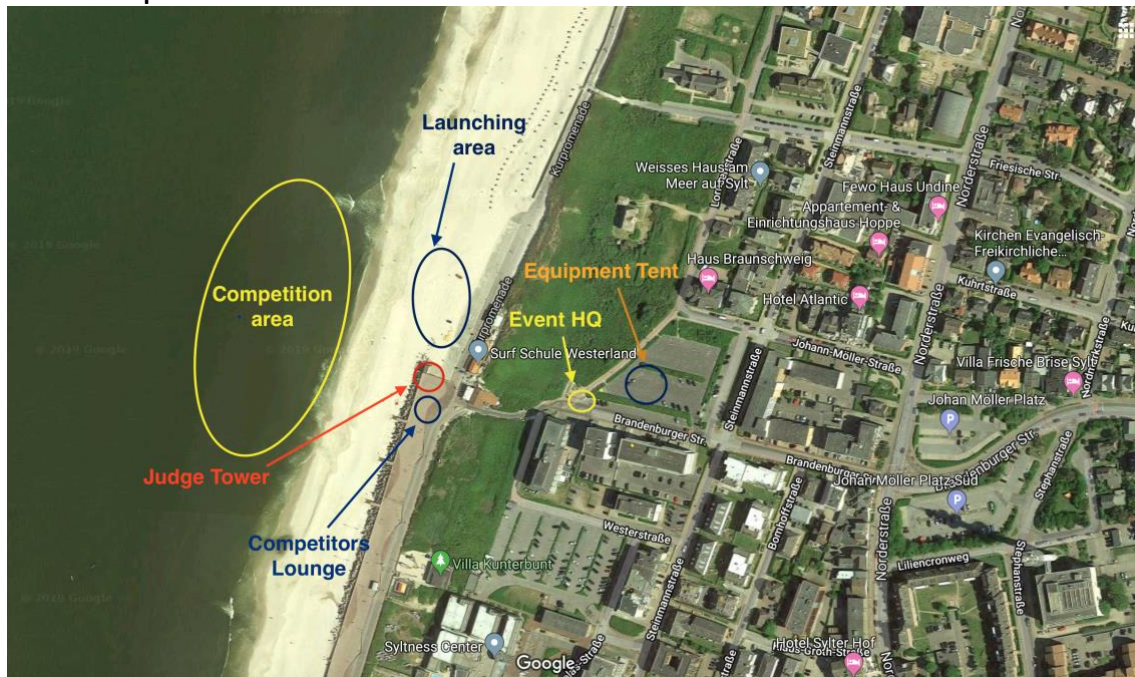

**Accommodation for competitors:**

Free accommodation for the Top 12 riders (male) and Top 4 riders (female) of the current seeding list of the official GKA Kitesurf World Tour in flats for 2 people- from the day before inscription through one day after the event (24.6.-1.7.2019)

For accommodations contact:

Insel Sylt Tourismus Service

Phone: +49 4651 998 0

Fax: +49 4651 998 6000

[info@westerland.de](mailto:info@westerland.de)

[www.insel-sylt.de](http://www.insel-sylt.de)

In addition to the Tourism Service Sylt, riders can also use the following contact details to book accommodation:

Apartment Brünig

Strandstraße 13

25980 Westerland / Sylt

Tel: +49 4651 5858

[bruening-sylt@t-online.de](mailto:bruening-sylt@t-online.de)

[www.appartement-bruenig.de](http://www.appartement-bruenig.de)



Wiking Apartement Agency  
Steinmannstraße 7-9  
25980 Westerland /Sylt  
Tel: +49 4651 83001  
[info@wikingsylt.de](mailto:info@wikingsylt.de)  
[www.wiking-sylt.de](http://www.wiking-sylt.de)

There are also possibilities at the local campsite which has fixed caravans for rent (properly equipped with heating, lighting power etc). These are available according to the following details.

Campingplatz Westerland  
Süderstraße 66  
25980 Westerland / Sylt  
Tel: +49 4651 299 19 39  
[info@duenencamping-westerland.de](mailto:info@duenencamping-westerland.de)  
[www.duenencamping-westerland.de](http://www.duenencamping-westerland.de)

#### Event parking:

It is possible to park with a van or a camper at the event parking "Brandenburger Strand" next to the equipment tent. For parking you need a parking permission, which you get from the organizer.  
**IMPORTANT:** Camping and overnight parking is officially prohibited.

#### **Prize money**

The prize money for the GKA KITE-SURF WORLD CUP 2019 held in Sylt, Germany will be **30.000 Euro**. The prizemoney is paid directly by the organizer to the competitors in line after the closing ceremony on the last day of the event. The organizer will subtract the individual withhold tax from the respective individual prizemoney amount. Rider can hand in the receipts for their event related travel and accommodation expenses to make those expenses tax-deductable. Only receipts handed in BEFORE the payment of prizemoney will be recognised!

27.000 Euro will be paid to the winners of the event and 3.000 Euro (10% of the event prizemoney) will go to the first 3 male and female winners of the GKA Kite-Surf World Tour end of year ranking, World Championship Title.

In the case of "no results" due to an Act of God (i.e. bad weather, no wind) 20.000 Euro of the total prizemoney will be distributed equally amongst all riders entered in the event. 3.000 Euro will be kept in the GKA account for the prizemoney to be paid out to the first three male and female winners of the GKA Kite-Surf World Tour end of the year. 7.000 Euro will be retained to the organizer.



The prize money distribution for a valid and completed KSWT event will be done according to the following table:

Single & Dingle:

MALE	
Position	Percentage
1	30,00%
2	22,50%
3	15,00%
4	8,74%
5	5,94%
5	5,94%
5	5,94%
5	5,94%
<b>Total</b>	<b>100%</b>

FEMALE	
Position	Percentage
1	40,00%
2	30,00%
3	20,00%
4	10,00%
<b>Total</b>	<b>100%</b>

Double:

MALE	
Position	Percentage
1	30,00%
2	22,50%
3	15,00%
4	8,75%
5	7,50%
6	6,25%
7	5,00%
7	5,00%
<b>Total</b>	<b>100%</b>

FEMALE	
Position	Percentage
1	40,00%
2	30,00%
3	20,00%
4	10,00%
<b>Total</b>	<b>100%</b>

Woman's prize division will be a minimum of 20% with 6 participants and will increase depending on the final number of woman competitors in proportion of the number of men competing. The maximum prize money allocated to women division will be 50% of the total prize money. If the women's division doesn't take place, the full amount allocated as prize money will be added to the men's division.

Different scenarios:

	Participants	Percentage
Men	32	80%
Woman	6	20%
<b>Total</b>	<b>38</b>	

	Participants	Percentage
Men	32	70%
Woman	16	30%
<b>Total</b>	<b>48</b>	



Eligibility

A competitor is eligible for any KSWT event if he meets the following conditions:

- (i). He is a member of his Official National Kiteboarding Federation or Association.  
A valid membership card or certificate, or other satisfactory evidence of identity and membership may be requested.
- (ii). He has a personal medical insurance with worldwide coverage. A valid membership card or certificate, or other satisfactory evidence of worldwide medical coverage may be requested.
- (iii) The competitor cannot hold the KSWT, the GKA or the event-organizer responsible for any claims for damages as a consequence of the competitor not having sufficient personal medical insurance.
- (iv) The competitor cannot hold the KSWT, the GKA or the event-organizer responsible for any legal liabilities and/or any claims for damages by third parties caused by the competitor.
- (v). He complies with World Sailing Federation Regulation, Eligibility Code

Entry allocation

Entries into KSWT events shall be allocated according to the following table:

CATEGORY	32 Riders	24 Riders	16 Riders	12 Riders
Current KSWT Seeding	1-22	1-16	1-12	1-9
GKA Wildcard	23-28	17-20	13-14	10
National Ranking or Organizer Wildcard	29-32	21-24	15-16	11-12

In the case that there is no National Qualifier Ranking, the spots will be allocated sharing between KSWT and Organizer Wildcards

Two weeks before the event, Local Organizer Wildcards shall be approved by the KSWT Sports Commission.

If any ranked competitor cannot compete in one KSWT event due to an injury or other reasons, the empty spot will be given to the next highest ranked competitor.

At the first event that a competitor will compete after an injury, if their ranking is below 24<sup>th</sup> for men or 12<sup>th</sup> for women, their entry will be granted as GKA wildcards.

There is a maximum number of 32 male competitors and 16 female competitors entering an event. The restrictions will be used in the following order:

- (i) For top positions, riders with a better current ranking have priority.



- (ii) For GKA wildcards, the KSWT Sports Commission will select competitors based on their participation in 2018 and 2017 KSWT events as well as their kiteboarding merits.
- (iii) For riders with no ranking, kiteboarding merits as well as video footage may be requested and used for selection.

Seeding and Elimination Procedure

The current KSWT Ranking will be seeded in the ladder according to the following:

- (a) For the first KSWT event, seeding will be based as follows:
  - (i). The previous year KSWT annual ranking results as 100% of their score.
- (b) After one (1) valid KSWT event, seeding for the second event will be based as follows:
  - (i). The first current year KSWT event results as 50% of their score.
  - (ii). The previous year KSWT annual ranking results as 50% of their score.
- (c) After two (2) valid KSWT events, seeding for the third event will be based as follows:
  - (i). The current year KSWT event results after two (2) events as 66.6% of their score.
  - (ii). The previous year KSWT annual ranking results as 33,3% of their score.
- (d) After three (3) valid KSWT events, seeding for the next events will be based in the current year KSWT ranking.

The seeding list for the GKA Kite-Surf World Cup Germany 2019:

Men	Name
1	COZZOLINO
2	MONTEIRO
3	LOPES
4	CAREW
5	RIBEIRO
6	PEREIRA.
7	RIVERAS
8	CAPUZZO
9	MATOS
10	MYERSCOUCH
11	DELANNOY
12	NUNES
13	DIAS
14	AMORES
15	BOELEN
16	PISU

Women	Name
1	WHYTE
2	EDIN
3	CARPENTIER
4	CORREIA
5	HERRERA
6	CAVIN
7	LOPES
8	KELLY
9	BEUKELEERS
10	HARLAN
11	JENNI
12	CASABURO
13	SCHWARTZTRAUBER



17	CILIBERTO
18	DELL'OMO
19	ABADJIEV
20	AFONSO
21	REBOUCAS
22	SILVA
23	MARIN
24	BARROS
25	MARIN
26	ROIG
27	LOPES
28	BETTENCOURT
29	SANCA
30	NEVES
31	MILLARD
32	ANDRADE
33	LOPES
34	COZZOLINO
35	FISCHER
36	MACIAS
37	PEREZ
38	DE SERIO
39	LUCAS

Elimination shall be single, dingle or double eliminations.



32 Rider Single/Double Elimination:

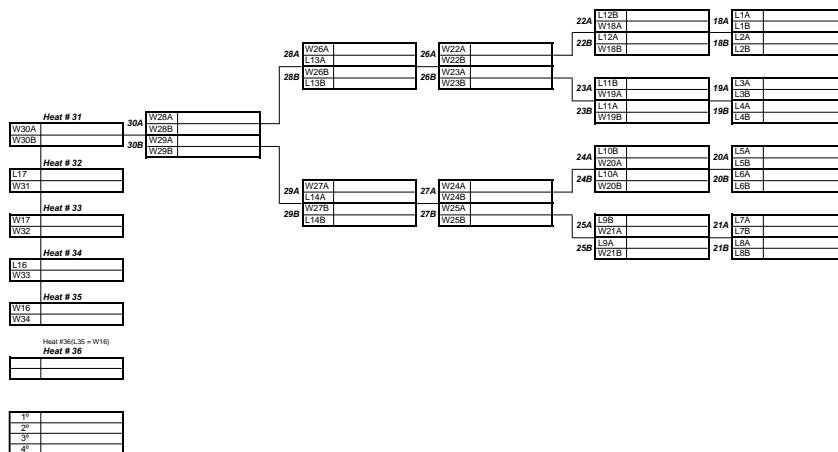
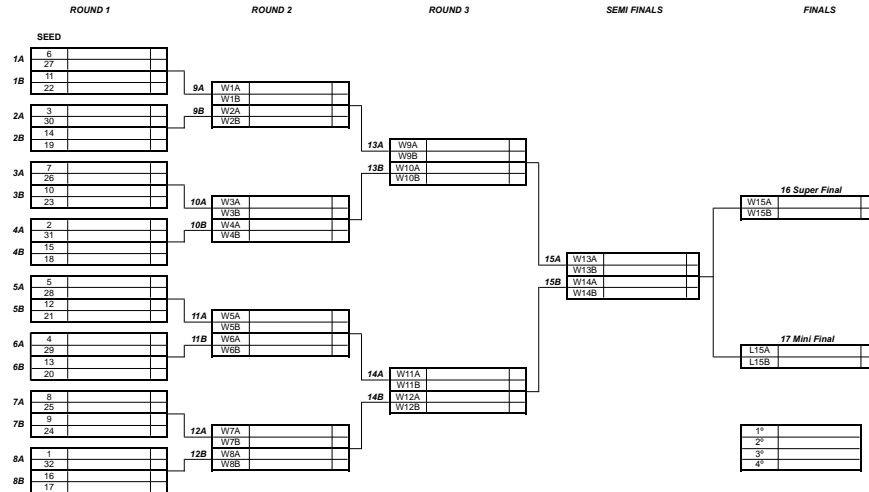



16 Rider Single/Double Elimination:

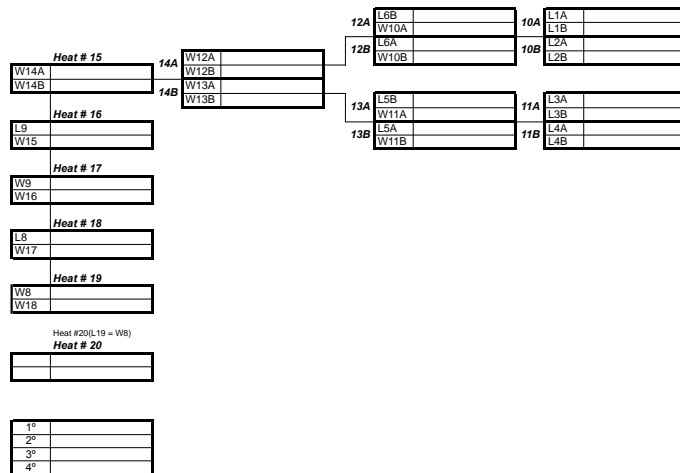
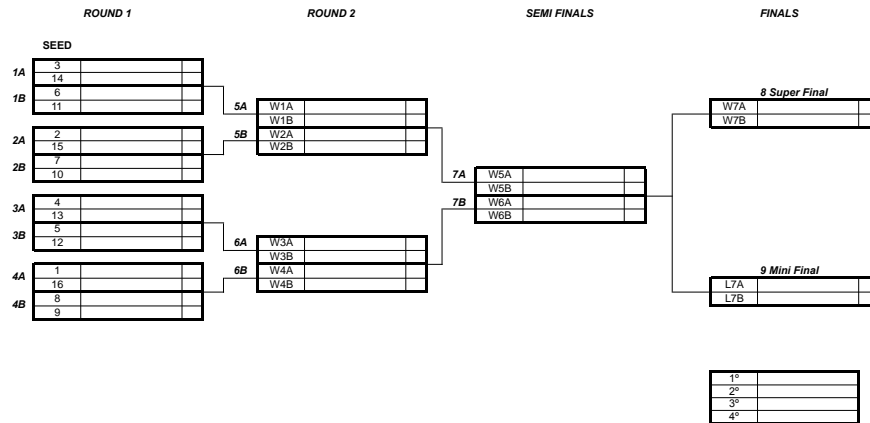





The Elimination procedure shall be:

- (i) competitors' names shall be entered on the appropriate elimination ladder for the first elimination series according to the event Seeding List and the seeding distribution table below.
- (ii) If there isn't a previous year nor a current ranking, competitors will be distributed in the KSWT ladder according to the name drawing that shall be done by the Contest Director at the first day mandatory meeting for all competitors before the competition starts.
- (iii) "Byes", if any, shall be positioned so that they are allocated to the most highly ranked competitors.
- (iv) competitors shall sail one against one in pairs, or in groups of up to 8 determined by the elimination ladder. The declared winner of each pair or the top half of the large groups shall advance on the elimination ladder. Once a round is started, the format shall stay the same until that round is completed. The format refers to either one on one or groups with the top half advancing.

### Scoring

Scoring Categories and Judging Criteria:

#### **(1) Wave:**

- (i) The maximum number of waves ridden attempts per competitor during a heat will be announced by the Head Judge and posted in the Official Notice Board at least thirty (30) minutes before the start of the heat.
- (ii) Each Wave ridden is scored from 0.1 to 10.0 (ten), broken into one-tenth increments (e.g 6.4).
- (iii) The following scale may be used to describe a wave ridden that is scored:
  - 0–1.9 = Poor;
  - 2.0–3.9 = Fair;
  - 4.0–5.9 = Average;
  - 6.0–7.9 = Good;
  - 8.0–10.0 = Excellent.
- (iv) **Judging Criteria** are applied to score individual waves ridden. Each judge analyzes the following major elements when scoring a ride:

- **Commitment.**
- **Degree of difficulty.**
- **Innovative and progressive maneuvers.**
- **Combination of major maneuvers.**
- **Variety of maneuvers.**
- **Speed, power and flow**



(v) The number of waves ridden from each competitor towards the final result shall be decided by the Head Judge in consultation with the Riders Representative and posted in the Official Notice Board at least thirty (30) minutes before the start of the heat.

(vi) If a judge misses a wave ride, or part of the wave ride, they should place an "M" and that score will be given points equal to the average to the nearest tenth of a point (0.05 to be rounded upward) of the other judges' scores.

(vii) The Head Judge may re-run the heat according to rule 22.1.4, if all judges miss a wave ridden and there is strong evidence that the wave ridden was missed by all the judges and this wave ridden had a scoring potential that may change the final result. It's important to note that the emphasis of certain elements is contingent upon the location and the conditions on the day, as well as changes of conditions during the day.

Competitors must combine the major key elements in order to be awarded scores in the excellent range.

## **(2) Strapless Freestyle:**

(i) The competition area shall be defined in the Sailing Instructions or in the way indicated in the Official Notice Board at least fifteen (15) minutes before the start of the heat. A diagram is recommended.

(ii) Competitors shall be scored while being in the designated competition area. Whether a competitor is in or out of the competition area, will be at the discretion of the senior judge on the relevant panel and the Head Judge.

### **(iii) Overall Impression Scoring:**

There is no limitation in maximum number of trick attempts per heat.

Judges will not assign numerical values to each tricks. They will have a shorthand notation for taking brief notes of the jumps performed on each tack during the heat. They will also write a final score based on the following categories:

\* 10 points Technical Difficulty: The technical difficulty and height of a trick landed during the heat. As the wind conditions increase, this aspect will exponentially become more and more into consideration, but only when the height is achieved along with risk factor and technical difficulty.

\* 10 points Variety: Variety of tricks completed during the heat on both tacks.

Repetition of tricks on the same tack will decrease the chances of winning the heat.

Repetition of tricks on both tacks (switch tricks) will increase the chances of winning the heat.



\* 10 points Overall impression: Considering style, quality vs quantity, innovation and “wow” factor.

**(iv) Trick by trick Scoring:**

There is no limitation in maximum number of trick attempts per heat.

Only the best 5 tricks with the highest individual scores from different trick categories will count towards the final score from each competitor. One per category, except BOARD OFF and KITE LOOP categories, that can count two.

The amount of trick attempt to count towards the final score will be announced by the Head Judge and posted in the Official Notice Board at least thirty (30) minutes before the start of the heat.

(v) If a competitor “butt checks” when landing the trick and doesn’t lose the board, the judges will still give some credit to the trick. It’s at the discretion of each judge to consider if it’s a crash or a butt check and to consider how much credit they will give to the trick.

(vi) The credit given to butt checked trick landings is directly related to the risk factor involved in the execution of the trick. For tricks with a high degree of risk factor, judges won’t deduct points for a butt-checked landing.

(vii) A trick is a crash only if the majority of the judges consider it as a crash. If the minority of the judges consider a trick as a crash, those crashes will be withdrawn and the judges will reconsider the trick in the other scoring categories

(viii) If a judge misses a trick, he should place a “M” and he has to consult to the Head Judge before giving the final score of the heat.

(ix) The Head Judge may re-run the heat if all judges miss a trick and there is strong evidence that the trick was missed by all the judges and this trick may change the final result.

(x) Judges may not change their scores. If there are any mistake the judge should have the Head Judge make the correction for them.

(xi) In case of tie, it will be broken in favor of the competitor with the highest single score. If a tie remains between two or more competitors, each competitor’s individual scores shall be listed in order of best to worst, even if some of them are excluded scores, and at the first point where there is a difference the tie shall be broken in favor of the competitor with the best individual score.



Trick categories:

The tricks repertoire has been broken down into the following tricks families. The list of tricks included by family is not extensive, and not limited to the described tricks below but gives an indication about how different tricks are being categorized by the judges. The Head Judge has the final say when categorizing a new trick.

## GKA KITE SURF WORLD TOUR TRICK LIST 2019

\*Any trick with a surface handle pass gets some extra points if done properly  
\*Any trick done with graps gets less points.

AIR TRICKS (1 TRICK)		BOARD OFFS (2 TRICKS)		KITELOOPS TRICKS (2 TRICKS)	
AIR	AIR	ONE FOOT	OF	KITELOOP	KL
AIR TO BLIND	A2B	FRONT ROLL ONE FOOT	FR0F	KITELOOP BACKROLL BOARD	KLBRBO
BODY 360	B360	FRONT ROLL BOARD OFF	FRBO	KITELOOP BACKROLL	KLBR
AIR REVERSE	AR	FRONT ROLL TIC TAC	FRTT	KITELOOP DOUBLE BACK ROLL	KL2BR
AIR FRONT SIDE 180 S.PASS	AFS180SP	BOARD OFF	BO	KITELOOP TIC TAC	KLTT
AIR 360	A3	TIC TAC	TT	KITELOOP FRONTROLL	KLFR
TOESIDE AIR	TSA	DOUBLE TIC TAC	2TT	KITELOOP FRONTROLL RODEO	KLFRR
TOESIDE FRONT SIDE 180 S.PASS	TFS180SP	BACK ROLL ONE FOOT	BR0F	KITELOOP RODEO	KLR
TOESIDE AIR REVERSE	TSAR	BACK ROLL BOARD OFF	BRBO	KITELOOP RODEO BACKROLL	KLRBR
TOESIDE AIR 360	TSA3	BACK ROLL SUPERMAN	BRS	KITELOOP RODEO FRONTROLL	KLRFRR
TOESIDE AIR 540	TSA5	BACK ROLL TIC TAC	BRTT		
TOESIDE AIR 720	TSA7	BACK ROLL DOUBLE TIC TAC	BR2TT	KICK TRICKS (SHOVE-IT) (1 TRICK)	
		BACK ROLL TRIPLE TIC TAC	BR3TT	SHOVE-IT	SH
		BACK ROLL TIC TAC FLIP	BRTF	SHOVE-IT 3	SH3
		BACK ROLL DOUBLE TIC TAC FLIP	BR2TF	SHOVE-IT 5	SH5
		FLIP	FL	SHOVE-IT 7	SH7
		HAND STAND	HS	ONE FOOT SHOVE-IT 3	OFSH3
		HAND STAND 360	HS360	VARIAL FLIP	VFL
		HAND VARIAL	HV	FLIP 3	FL3
		JESUS WALK	JW	FRONTSIDE BIG SPIN	FSBS
		BARE FOOT	BF	BACKSIDE BIG SPIN	BSBS
		FRONT ROLL HAND VARIAL	FRHV	BACK ROLL SHOVE IT 3	BRSH3
				FRONT ROLL SHOVE IT 3	FRSH3
		RODEO TRICKS (1 TRICK)		FRONT ROLL SHOVE IT 5	FRSH5
		RODEO	R	FRONT ROLL SHOVE IT 7	FRSH7
		TIC TAC RODEO	TTR	DOUBLE FRONT ROLL SHOVE IT 3	2FRSH3
		BACK ROLL RODEO	BRR	TOESIDE FRONT ROLL SHOVE IT 3	TFRSH3
		DOUBLE BACK ROLL RODEO	2BRR		
		TRIPLE BACK ROLL RODEO	3BRR		
		BACK ROLL TIC TAC RODEO	BRTR		
		BACK ROLL DOUBLE TIC TAC RODEO	BR2TR		
		BACK ROLL TIC TAC RODEO FLIP	BRTFR		
		BACK ROLL SHOVE IT 3 RODEO	BRSH3R		
		FRONT ROLL RODEO	FRR		
		DOUBLE FRONT ROLL RODEO	2FRR		
				HANDLE PASS TRICKS (1 TRICK)	
		FRONTSIDE 360	FS3		
		BACKSIDE 360	BS3		
		SHIFTY FRONTSIDE 360	SFS3		
		TOESIDE FRONTSIDE 360	TSFS3		
		HANDLE PASS RODEO	HPR		

In order to bring the variety criteria into effect, only the highest score per trick family will count towards the final heat score from each competitor.



### Judging Criteria:

Judges will assign numerical values to each trick attempt based on the following judging criterias:

(i) Height and amplitude – The combination of height and amplitude of the tricks completed during the heat. As the wind conditions increase, this aspect will exponentially become more and more into consideration, but only when the height and amplitude are achieved along with risk factor and technical difficulty.

(ii) Technical Difficulty – The technical difficulty of tricks completed during the heat. A grabbed trick will be rewarded with a higher score than a non-grabbed trick within this criteria, depending on the quality of the execution.

(iii) Power – The power during the execution of the tricks. Power will be considered as a combination of speed into the trick to pop and speed out during the landing, height and amplitude during the trick.

(iv) Risk factor – Is directly linked to the power, height, amplitude and technical difficulty of the jump, but also to the commitment of the competitor and physical challenge during the execution, duration of the critical moment, and energy on the execution.

(v) Smoothness – Smoothness and fluidity during the execution and landing of tricks completed during the heat.

(vi) Innovation – Tricks that have never been landed in competition before.

### Equipment

Only Surf-boards are eligible for use in competition.

In the Wave category footstraps, pads and wax are allowed.

For men division, in the Strapless Freestyle category, only boards with pads are allowed. Footstraps and wax are not allowed.

For women division, in the Strapless Freestyle category, only boards with pads and wax are allowed. Footstraps are not allowed.



## **GKA Staff at the Kite-Surf World Cup Germany 2019**

**General Secretary:** Dr Jürgen Vogt

**Tour Manager:** Tom Hartmann

**Race Director:** Juan Antonio Aragon

**Head Judge:** Daniel Jimenez

**Judge:** Mallory Hersart de la Villemarque

**Judge:** Alvaro Onieva

**Judge:** Fadi Issa

**Judge:** Luis de Dios

**Judge:** Tanja Rosenkranz

**Assistant:** Janne Vollert

**Press Officer:** Matthew Pearce

**Social Media:** Rasa Iselionyte

**Foto:** Svetlana Romantsova

**Video:** Mintautas Grigas

## **Rulebook**

The "GKA Kite World Tour Rulebook 2019 – Discipline Kite-Surf" is available for download on the official GKA Kite World Tour website:

<https://www.gkakiteworldtour.com/rulebooks/2019/GKA%20Kite%20World%20Tour%20Rulebook%202019%20-%20Discipline%20Kite-Surf.pdf>

Any question please contact our Tour Manager Tom Hartmann at [tom@global-kitesports.org](mailto:tom@global-kitesports.org)

We look forward to seeing you very soon!

## **The GKA Team**

\* **5-STAR World Cup** includes (1) Livestream, (2) International TV coverage and (3) 30.000,- Prizemoney.

**4-STAR World Cup** includes 2 out of the 3 assumptions of a 5-STAR World Cup.

**3-STAR World Cup** includes 1 out of the 3 assumption of a 5-STAR World Cup.